

# FILTRABOX

EXPAND, COMPACT & BASYS

FOR:  
**EPILOG**  
LASER

“Filtrabox™ ticks all the boxes for my customers.  
Lower initial purchase price, lower operating costs  
while improving filtration capacity and performance”

- Mike Dean, Vice President, Sales & Marketing Epilog Laser



- Lowest Operating & Equipment Cost
- Certifications: CE 
- Epilog Approved

# Specifications

## Compact

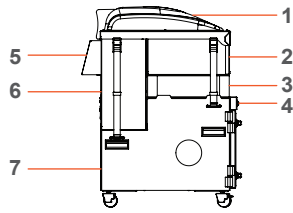

### Technical Specifications

Quiet operation	50 db
Height	31 in.
Width	21 in.
Depth	25 in.
Glassfiber pre-filter capacity	7 m <sup>2</sup>
Glassfiber HEPA filter capacity	6 m <sup>2</sup>
Carbon filter capacity	1x41 lbs
Voltage	230/120 V
Frequency	50-60 Hz
Wattage	1.1 kW
Warranty	1 year

## Expand 1

Single Blower

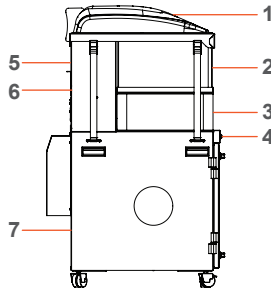

### Technical Specifications

Quiet operation	50 db
Height	44 in.
Width	29 in.
Depth	28 in.
Glassfiber pre-filter capacity	30 m <sup>2</sup>
Glassfiber HEPA filter capacity	12 m <sup>2</sup>
Carbon filter capacity	2x41.5 lbs
Voltage	230/120 V
Frequency	50-60 Hz
Wattage	1.1 kW
Warranty	1 year

## Expand 2

Dual Blower

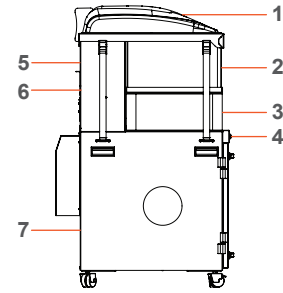

### Technical Specifications

Quiet operation	53 db
Height	44 in.
Width	29 in.
Depth	28 in.
Glassfiber pre-filter capacity	30 m <sup>2</sup>
Glassfiber HEPA filter capacity	12 m <sup>2</sup>
Carbon filter capacity	2x41.5 lbs
Voltage	230/120 V
Frequency	50-60 Hz
Wattage	2.2 kW
Warranty	1 year



### Legend:

- |                          |                      |                               |                          |
|--------------------------|----------------------|-------------------------------|--------------------------|
| 1) Lid Module w/ sensors | 2) Oxy-Carbon Filter | 3) Rigid Aluminum Hepa Filter | 4) User Interface Module |
| 5) Electronics Module    | 6) Blower Module     | 7) Pre-Filter Housing/Chassis |                          |

## Basys

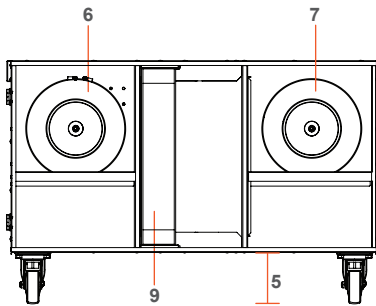

FRONT (DOOR HIDDEN)

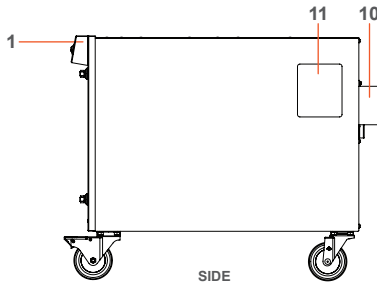

SIDE

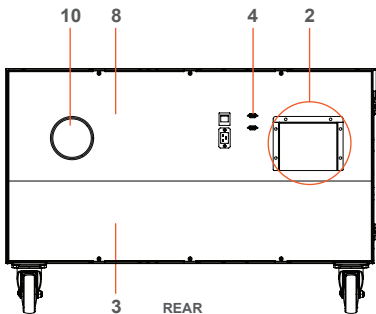

REAR

### Legend:

- 1) User Interface Module
- 2) High Pressure Blower Module w/ Sensor
- 3) Compressor Compartment
- 4) EZ-Link
- 5) Kick Plate Space
- 6) Oxy-Carbon Filter
- 7) Pre-Filter
- 8) Electronics Module
- 9) Rigid Aluminum Hepa Filter
- 10) 4" Inlet
- 11) Exhaust

### Technical Specifications

Quiet operation	50 db
Height	24"
Width	38"
Depth	28"
Glassfiber pre-filter capacity	7 m <sup>2</sup>
Glassfiber HEPA filter capacity	6 m <sup>2</sup>
Carbon filter capacity	20 lbs
Voltage	230/120 V
Frequency	50-60 Hz
Wattage	1.1 kW
Warranty	1 year

For more information please call Filtrabox™  
at +1 514-840-9696 (Local)  
or +1 877-582-7929 (International)